

3 Prebijalna igla

Cutting Punch



Povrtnalna rezila

Countersink tool

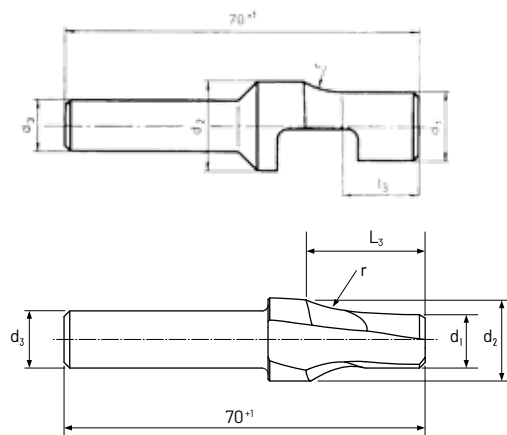

Grezilno orodje s pozavnasto rezilno iglo - eno in tri stranskim prirezovalnikom.

Countersink tool for bottle-neck punch with one or three - side trimmer.

Obseg uporabe:

Grezilno orodje s pozavnasto rezilno iglo - enostranski ali tristranski prirezovalnik.

Dimenzije so prikazane v tabeli.

Material:

HSS (Hitrorezna jekla)

Št. materiala:

- 1.3343(S 6-5-2)

Karakteristike:

HSS: ekstremno visoka trpežnost, za materiale s katerimi se težko dela. Velika odpornost proti obrabi. Visoka natezalna trdnost, visoka odpornost proti vročini.

Obdelava:

Kaljeno, napuščeno in polirano.

Range of application:

Countersink tool for bottle-neck punch with one - side or three side trimmer.

The dimensions are shown in the table.

Material:

HSS (High speed steels)

Material Number:

- 1.3343(S 6-5-2)

Material properties:

HSS: Extremely high durability for materials which are difficult to process. High abrasion resistance. High tear strength, high heat resistance.

Finish:

Hardened, tempered and grounded.



d1 f7	d2 h8	d3 h11	r + 0,2	L3	70 ₋₁
≥ 2,0	3,3	3,3	3,5	5,0	●
≥ 2,1	3,5	3,5			●
≥ 2,3	3,8		5,0		●
≥ 2,5	3,8	3,8	5,0		●
≥ 2,6	4,3		6,5	7,0	●
2,7		4,3			●
≥ 3,0	4,9				●
3,1		4,9			●
3,3					●
≥ 3,5	5,4		8,0		●
3,6		5,4			●
≥ 4,0	5,9	5,9		8,0	●
4,1					●
4,2					●
4,3					●
≥ 4,5	6,4	6,4			●
4,8					●
≥ 5,0	7,4	7,4	10,0	10,0	●
5,2					●
≥ 5,5	8,5				●
5,7		8,5			●
5,8					●
≥ 6,0	9,5				●
≥ 6,5	10,5	10,5	12,0	12,0	●
7,0					●
≥ 7,5	11,5	10			●
8,0					●
≥ 8,5	13,5	10	15,0	12,0	●
9,0					●
≥ 9,5	14,5				●
10,5					●
≥ 10,5	15,5			15,0	●
11,0					●
≥ 11,5	16,5				●
12,0					●
≥ 12,5	17,5				●
13,0					●
≥ 13,5	18,5				●
14,0					●
≥ 14,5	19,5				●
15,0					●
≥ 15,5	20,5				●
16,0					●
≥ 16,5	21,5	16			●
≥ 17,5	22,5				●
≥ 18,5	23,5				●
19,0					●
≥ 19,5 - 20,0	25,5				●