

3 Prebijalna igla Cutting Punch

DIN 9861 D

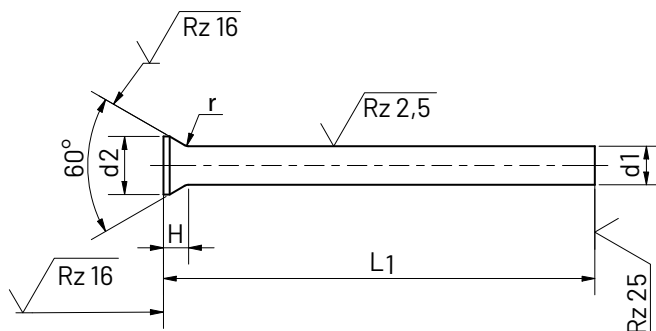

Rezilna igla z ugrezno glavo.

Cutting Punch with a Countersunk head.

Dimenzije so prikazane v tabeli.

Material:
Vanadis 23

Na voljo tudi v drugih materialih.
Poglejte tabelo materialov.

Trdota:
Steblo: HRC 64 ± 2
Glava: HRC 50 ± 2

The dimensions are shown in the table.

Material:
Vanadis 23

Other materials available on request,
see table.

Hardnes:
Shank: HRC ca 53
Head: HRC ca 45

Ø d1 h6	d2 ± 0,05	h + 0,20	r	L1 +0,5		
				71	80	100
1,00	1,8	1,19	0,4+0,30	•		•
1,10		1,11		•		•
1,20	2,0	1,19		•		•
1,30		1,11		•		•
1,40	2,2	1,19		•		•
1,50		1,11		•	•	•
1,60	2,5	1,28		•	•	•
1,70		1,19		•	•	•
1,80	2,8	1,37		•	•	•
1,90		1,28		•		•
2,00	3,0	1,37	0,4+0,30	•	•	•
2,10	3,2	1,45		•	•	•
2,20		1,37		•		•
2,30	3,5	1,54		•	•	•
2,40		1,45		•		•
2,50		1,37		•	•	•

Ø d1 h6	d2 ± 0,05	h + 0,20	r	L1 +0,5		
				71	80	100
2,60						•
2,70	4,0	1,63	0,4+0,30	•	•	•
2,80		1,54		•	•	•
2,90		1,45		•	•	•
3,00	4,5	1,80	0,6+0,40	•	•	•
3,10		1,71		•	•	•
3,20		1,63		•	•	•
3,30		1,54			•	•
3,40		1,45		•		•
3,50	5,0	1,80		•	•	•
3,60		1,71		•		•
3,70		1,63				•
3,80		1,54				•
3,90		1,45		•		•
4,00	5,5	1,80		•	•	•



Ø d1 h6	d2 ± 0,05	h + 0,20	r	l1 +0,5		
				71	80	100
4,10		1,71		•	•	•
4,20		1,63			•	•
4,30		1,54		•		•
4,50	6,0	1,80		•	•	•
4,60		1,71		•	•	
4,70		1,63				•
5,00	6,5	1,80	0,6+0,40	•	•	•
5,10		1,71		•	•	•
5,20		1,63				•
5,30		1,54				•
5,50	7,0	1,80				•
5,60		1,71				•
6,00	8,0	2,23	1,0+0,50	•	•	•
6,10		2,15				•
6,20		2,06				•
6,50	9,0	3,17		•	•	•
6,60		3,08			•	
6,80		2,91				•
7,00		2,73		•	•	•
7,10		2,65				•
7,50		3,17		•	•	•
8,00		2,73		•	•	•
8,20		2,56				•
8,30		2,47				•
8,50	11,0	3,17				•
9,00		2,73		•	•	•
9,20		2,56				•
9,50	12,0	3,17		•		
10,00		2,73		•	•	•
10,50	13,0	3,17		•		•
11,00		2,73		•		•
12,00		2,73		•	•	•
12,50	15,0	3,17				•
13,00		2,73				•
14,00		3,23				•
16,00		3,23		•		•