

3 Prebijalna igla Cutting Punch

DIN ISO 8020 G

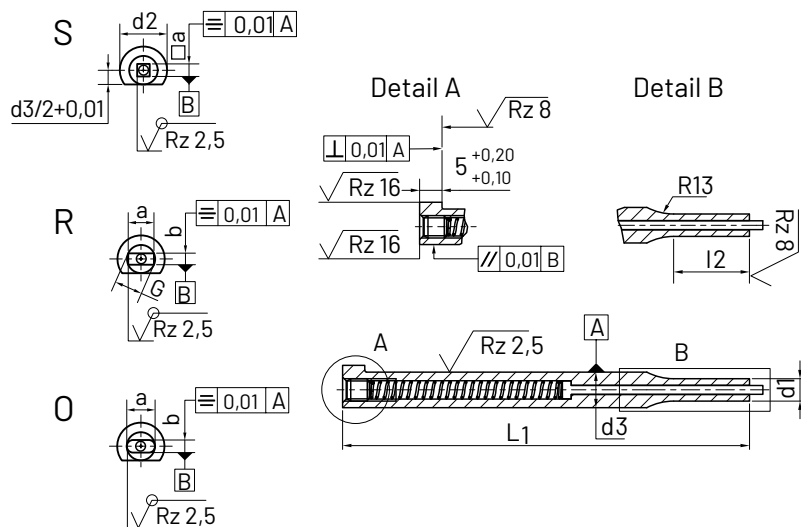

Prebijalna igla s cilindrično glavo.

Cutting Punch with
Cylindrical Head.

Obseg uporabe:

V rezilnih (prebijalnih) orodjih za rezanje lukenj v jeklo (perforacija). Posebej primerne za hiter izmet direktno iz matric.

Dimenzije so prikazane v tabeli.

Tipi:

- GS: reducirni del v obliki kvadrata with spring loaded pin
- GR: reducirni del v obliki pravokotnika z vzmetnim zatičem
- GO: reducirni del v obliki ovala / zaobljenega pravokotnika z vzmetnim zatičem

Material:

HWS (visoko legirno jeklo za delo v hladnem - 12% krom) / **HSS** (hitrorezno jeklo) / **ASP 23** (polprašno orodno jeklo Vanadis 23) / **HM** (karbidna kovina)

Različica in trdota:

Umestitev ravnega dela je vedno na daljši strani glede na smer na glavi. Če želite, vam lahko spremenimo orodje, da je ravna ploskev na krajši strani.

Range of application:

Cutting tools for cutting holes in steel. Especially suitable for fast ejection from the matrix.

The dimensions are shown in the table.

Types

- GS: square stepped cutting shaft with spring loaded pin
- GR: rectangular stepped cutting shaft with spring loaded pin
- GO: oblong stepped cutting shaft with spring loaded pin

Material:

HWS High alloy cold working steel (approx. 12% Chrome) / **HSS** (HSS steel) / **ASP 23** - non cobalt grade for high performance cutting tools, cold work tools / **HM** (hardmetall)

Version and Hardness:

Flat part is always on the longer side according to the direction on the head. If you want, we can change the tool for you, that the flat surface is on the shorter side.

Opomba | Note

Rezilni klini-izbijači niso na zalogi, vendar jih lahko izdelamo v kratkem času. Varnostni zaklop je vedno na dolgi strani. Na zahtevo lahko izdelamo varnostni zaklop proti zasuku tudi na kratki strani.

Cutting punches are not stocked, but can be produced at short notice. The anti-twist lock is always at the longest form side. On request, we can manufacture the anti-twist lock at the short form side.



a ± 0,01	b ± 0,01	d ₂ 0 - 0,15	d ₃ m5	r + 0,1 0	L ₂ + 0,5 0	L ₁ + 0,5 + 0,2		
						71	80	90
		9	6	0,3		●	●	●
Na željo stranke G=max d ₃		11	8		Željene velikosti so 10, 13, 17;	●	●	●
		13	10		Možne tudi druge dolžine.	●	●	●
At costumers request G=max d ₃		16	13	0,4		●	●	●
		19	16		Preferred sizes = 10, 13, 17;	●	●	●
		23	20		Other lengths possible		●	●
		28	25				●	●

Dostava s križno luknjo je glede na razpoložljivost. / Delivery with cross hole is subject to availability.

Tipi profilov

Type variations

| Punches and dies

Naročite lahko tudi druge tipe profilov.

Izdelujemo jih po predloženih skicah iz različnih materialov: HWS, HSS in jekla iz prašne metalurgije. Na željo tudi prevleko.

We can supply these tools according to your requirements from a range of materials: HWS, HSS and powder metallurgic steels. Also coated if requested

